

EPR3000 Precision Pressure Regulator



EPR3000

Precision Pressure Regulator



Product Features

- High precision , sensitive response.
- Steady output pressure.
- Large flow rate and steady flow output.
- Easy installation : Independent installation by bracket ; Bottom installation; Direct installation with existing modular air preparation.
- High pressure type, medium pressure type and low pressure type optional.

How to Order?

Series No.	Port Size	Pressure Range	Pressure Gauge Code	Bracket Code	Scale Unit	Thread Type
EPR3000	02:1/4"	L:0.005 ~ 0.2MPa M:0.01 ~ 0.4MPa H:0.01 ~ 0.8MPa	Blank: With pressure gauge N: No pressure gauge	Blank: With bracket J: No bracket	Blank: MPa/Psi	Blank: G P: PT T:NPT

Order Example: EPR3000 high precision regulator , 1/4" port, pressure range 0.01~0.8MPa ,with gauge,with bracket,scale unit MPa/Psi ,G thread , ERP code is EPR3000-02-HJN

Specifications

Model No.	EPR3000
Working Medium	Clean air(After 40 μm filtration)
Max. supply pressure	1.0
Min. supply pressure	Setting pressure+0.05
Proof pressure	1.5
Setting pressure range	L:0.005 ~ 0.2MPa
	M:0.01 ~ 0.4MPa
	H:0.01 ~ 0.8MPa
Sensitivity	Within 0.2% of full scale value
Repeated accuracy	Within±0.5% of full scale value
Port size	1/4"
Pressure gauge port size	G1/8(2 place)
Working Temperature	-20~70 (No freezing)

Internal Structure

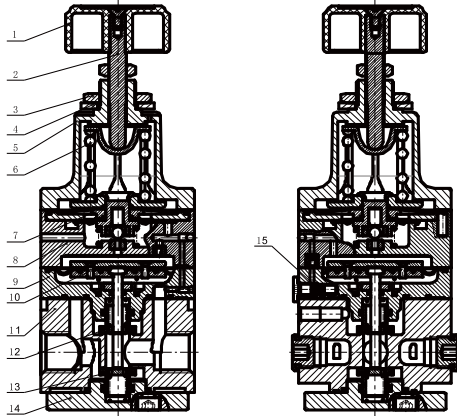

No.	Part Name	Material
1	Pilot regulate button	Plastic
2	Pilot regulate axle	Carbon steel
3	Hex nut	Free Machining Steel
4	Flat washer	SPCC
5	Pilot regulate seat	Aluminum
6	Spring	Spring steel
7	Pilot diaphragm assy	Assy
8	Nozzle	Aluminum
9	Middle valve body	Aluminum
10	Main regulate diaphragm	Assy
11	Main valve body	Aluminum
12	Exhaust valve core	Assy
13	Inlet valve core	Assy
14	Bottom cover	Aluminum
15	Filter element	High polymer material

Flow Chart

EPR3000 Flow rate characteristics

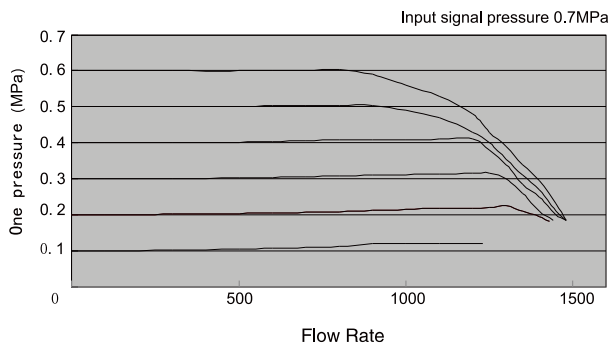

EPR3000 Pressure characteristics

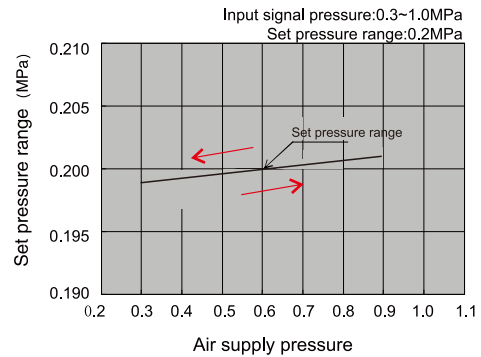

Main Dimension

